

### Specifications

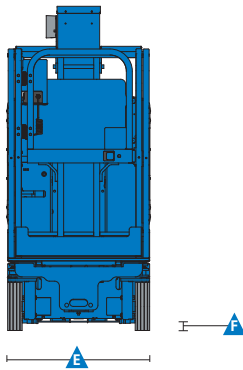
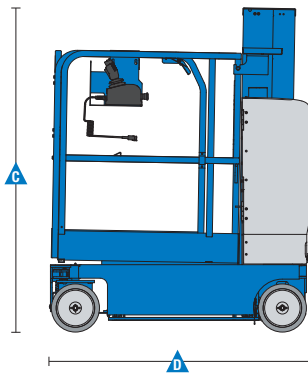
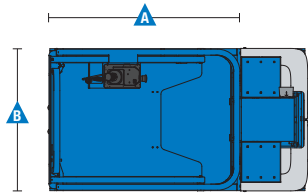

Models	GRC-12	
Measurements	US	Metric
Working height*	18 ft	5.65 m
Platform height	12 ft	3.65 m
<b>A B</b> Platform dimensions (length x width)		
Ext Platform dimensions - retracted	39 x 29.5 in	.99 x .75 m
Ext Platform dimensions - extended	55 x 29.5 in	1.4 x .75 m
<b>C</b> Height - stowed	67 in	1.70 m
<b>D</b> Length - stowed	4 ft 5.75 in	1.37 m
<b>E</b> Width ANSI, CSA	2 ft 5.5 in	.75 m
<b>F</b> Ground clearance - center	2.5 in	6 cm

### Productivity

Lift capacity	500 lbs	227 kg
Lift capacity - extension deck	250 lbs	113 kg
Drive speed - stowed	2.5 mph	4.0 km/h
Drive speed - raised	0.5 mph	0.8 km/h
Gradeability**	30%	
Turning radius - inside	zero	
Turning radius - outside ANSI/CSA	4 ft 4 in	1.32 m
Raise / lower speed	12 / 16 sec	12 / 16 sec
Controls	24V DC proportional	
Tires - solid non-marking	10 x 3 x 8 in	25 x 8 x 20 cm

### Power

Power source	24V (four 6V 225 Ah batteries)	
Hydraulic system capacity	2.2 gal	8.33 L

### Weight\*\*\*

ANSI, CSA	1,916 lbs	869 kg
-----------	-----------	--------

### Standards Compliance

ANSI A92.6, CSA B354.2, CE Compliance, AS 1418.10

\* The metric equivalent of working height adds 2 m to platform height. U.S. adds 6 ft to platform height.

\*\* Gradeability applies to driving on slopes. See operator's manual for details regarding slope rating.

\*\*\* Weight will vary depending on options and/or country standards.

## Features

### Standard Features

#### Measurements

##### GRC-12

- 18 ft (5.65 m) working height
- 12 ft (3.65 m) platform height
- Up to 500 lbs (227 kg) lift capacity

#### Productivity

- 2-person rated
- Steel platform and extension deck with swing gate
- Auxiliary platform lowering
- Steel tube-in-tube mast system
- Compact base 29.5 x 53.75 in (.75 x 1.37 m)
- Ground clearance 2.5 inches (stowed)
- SmartLink™ control system
- Battery charge indicator
- On-board diagnostic system
- AC power to platform
- Work station trays
- Descent and tilt alarm
- Zero inside turning radius
- Dual wheel brakes
- Hydraulic brake release
- Pothole protection
- Hinged rear ABS covers for easy access to all major electrical and hydraulic components
- Tie down attachment points
- Overhead crane attachment point
- Large forklift pockets access
- Non-marking solid tires
- Motion alarm

#### Power

- Automatic 19 amp battery charger

### Options & Accessories

#### Productivity

- Dual flashing LED beacons
- Fluorescent tube caddy
- Automotive horn
- EE Certification\*
- Biodegradable hydraulic oil
- Drive cutout while charging
- 10 ft retractable charging cord\*\*

#### Power

- 24V (four 6V 225 Ah batteries)
- 800 watt, 24V inverter (120-230V AC / 50-60 Hz)
- AGM maintenance-free batteries



\* Not available with automotive horn or inverter  
\*\* Not available with inverter