

Specifications

Model	Z-33/18	
Measurements	US	Metric
Working height maximum*	38 ft 10 in	12 m
Platform height maximum	32 ft 10 in	10 m
Horizontal reach maximum	18 ft 3 in	5.57 m
Up and over clearance maximum	14 ft 1 in	4.28 m
A Platform length	2 ft 6 in	0.76 m
B Platform width	3 ft 10 in	1.17 m
C Height - stowed	6 ft 6 in	1.98 m
D Length - stowed	13 ft 8 in	4.17 m
E Width	4 ft 11 in	1.50 m
F Wheelbase	6 ft 3 in	1.90 m
G Ground clearance - center	6.0 in	15.2 cm

Productivity

Lift capacity	440 lbs	200 kg
Turntable rotation	400° non-continuous	
Turntable tailswing at counterweight	zero	zero
Turntable tailswing - riser up	5.2 in	0.15 m
Turntable tailswing - riser down	3 ft 10 in	1.16 m
Drive speed - stowed	3.2 mph	5.2 km/h
Drive speed - raised retracted**	0.54 mph	0.87 km/h
Drive speed - raised extended**	0.14 mph	0.23 km/h
Gradeability - stowed***	30%	
Turning radius - inside	6 ft 3 in	1.9 m
Controls	24V DC proportional	
Tires (solid rubber, non-marking, treaded)	22x9x17 in	56x23x43 cm

Power

Power source	48 V DC (eight 6 V X 8 batteries 350 Ah capacity)	
Drive system	AC Drive, 48V 3 phase	
Auxiliary power unit	24 V DC	24 V DC
Hydraulic tank capacity	6 gal	20.8 L

Weight****

	8,080 lbs	3,665 kg
--	-----------	----------

Standards Compliance

ANSI A92.5, CSA B354.4, EN 280, AS 1418.10

* The metric equivalent of working height adds 2 m to platform height. U.S. adds 6 ft to platform height.
 ** In lift mode (platform raised), the machine is designed to operate on firm, level surfaces only.
 *** Gradeability applies to driving on slopes. See operator's manual for details regarding slope ratings.
 **** Weight will vary depending on options and/or country standards.

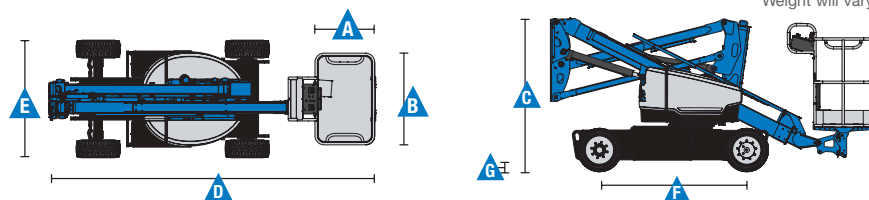

Range Of Motion Z-33/18

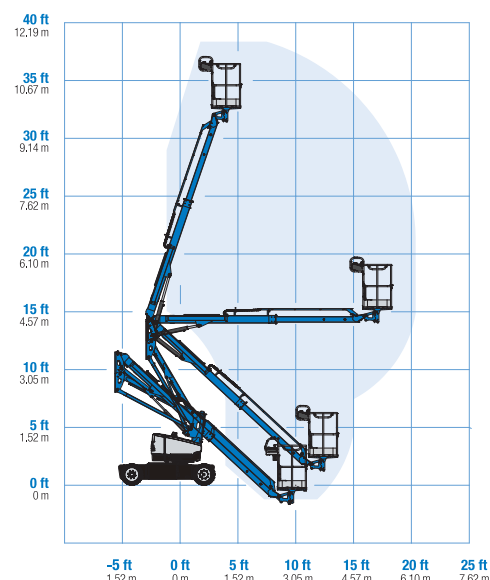

Features

Standard Features

Measurements

- 38 ft 10 in (12 m) working height
- 18 ft 3 in (5.57 m) horizontal reach
- 14 ft 1 in (4.28 m) up and over clearance
- Up to 440 lbs (200 kg) lift capacity with up to two occupants

Productivity

- Alarm package (flashing beacon and travel alarm)
- 4 ft 11 in (1.50 m) width
- 6 ft 3 in (1.9 m) inside turning radius
- Self-leveling platform
- Fast Mast™ System
- Proportional joystick controls
- Thumb rocker steer
- Drive enable
- Horn
- Hour meter
- Tilt alarm
- Descent & travel alarms
- 400° non-continuous turntable rotation
- AC electric drive system
- Traction control
- On board easy to understand diagnostics
- AC power cord to platform
- Entry toe board

Power

- 48 V DC deep cycle battery pack
- 24 V DC auxiliary power
- Universal 30A battery smart charger
- Battery charge indicator
- Low battery voltage interrupt

Easily Configured To Meet Your Needs

Platform

- Aluminum 3 ft 10 in (1.17 m) with sliding mid-rail

Power

- 48 V DC (eight 6 V 350 Ah batteries)

Drive

- 2WD, AC Electric

Tires

- Solid rubber non-marking

Options & Accessories

Productivity

- Air line to platform*
- Work lights package (2 on chassis, 2 on platform)
- Lockable platform control box cover
- Biodegradable hydraulic oil



* Factory fit option only