

Specifications

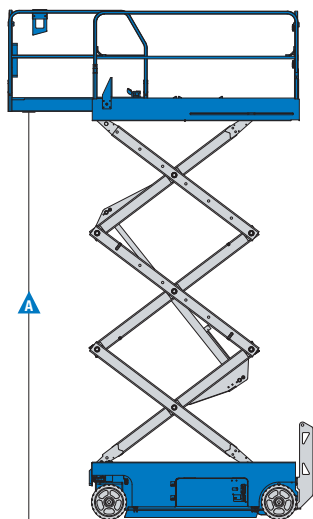
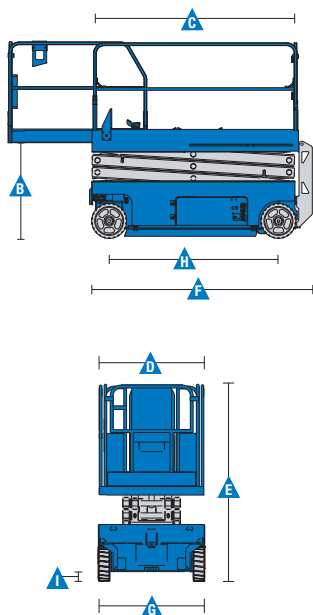

Models	GS-2046		GS-2646		GS-3246	
Measurements	US	Metric	US	Metric	US	Metric
Working height maximum*	26 ft	8.10 m	32 ft	9.92 m	38 ft	11.75 m
A Platform height maximum	20 ft	6.10 m	26 ft	7.92 m	32 ft	9.75 m
B Platform height stowed	3 ft 5 in	1.04 m	3 ft 10 in	1.16 m	4 ft 3 in	1.29 m
C Platform length - outside	7 ft 5 in	2.26 m	7 ft 5 in	2.26 m	7 ft 5 in	2.26 m
extended	10 ft 5 in	3.18 m	10 ft 5 in	3.18 m	10 ft 5 in	3.18 m
Slide-out platform extension deck	3 ft	0.91 m	3 ft	0.91 m	3 ft	0.91 m
D Platform width - outside	3 ft 9.5 in	1.16 m	3 ft 9.5 in	1.16 m	3 ft 9.5 in	1.16 m
Guardrail height	3 ft 7 in	1.09 m	3 ft 7 in	1.09 m	3 ft 7 in	1.09 m
Toeboard height	6 in	0.15 m	6 in	0.15 m	6 in	0.15 m
E Height - stowed: folding rails	7 ft	2.13 m	7 ft 5 in	2.26 m	7 ft 10 in	2.39 m
rails folded	5 ft 1 in	1.55 m	5 ft 6 in	1.68 m	5 ft 11 in	1.80 m
A Length - stowed	8 ft	2.44 m	8 ft	2.44 m	8 ft	2.44 m
extended	10 ft 11 in	3.33 m	10 ft 11 in	3.33 m	10 ft 11 in	3.33 m
G Width	3 ft 10 in	1.16 m	3 ft 10 in	1.16 m	3 ft 10 in	1.16 m
H Wheelbase	6 ft 1 in	1.85 m	6 ft 1 in	1.85 m	6 ft 1 in	1.85 m
I Ground clearance - center	3.75 in	10 cm	3.75 in	10 cm	3.75 in	10 cm
- with pothole guards deployed	0.75 in	2 cm	0.75 in	2 cm	0.75 in	2 cm

Productivity

Maximum platform occupancy**	4		3		2	
Lift capacity	1,200 lbs	544 kg	1,000 lbs	454 kg	700 lbs	318 kg
Lift capacity - extension deck	250 lbs	113 kg	250 lbs	113 kg	250 lbs	113 kg
Drive height	full height		full height		full height	
Drive speed - stowed	2.0 mph	3.2 km/h	2.0 mph	3.2 km/h	2.0 mph	3.0 km/h
Drive speed - raised	0.5 mph	0.8 km/h	0.5 mph	0.8 km/h	0.5 mph	0.8 km/h
Gradeability - stowed***	30%		30%		25%	
Turning radius - inside	zero		zero		zero	
Turning radius - outside	7 ft 6 in	2.29 m	7 ft 6 in	2.29 m	7 ft 6 in	2.29 m
Raise / lower speed	28 / 28 sec		28 / 28 sec		57 / 28 sec	
Controls	proportional		proportional		proportional	
Drive	dual front wheel		dual front wheel		dual front wheel	
Multiple disc brakes	dual rear wheel		dual rear wheel		dual rear wheel	
Tires - solid non-marking	15 x 5 in	38 x 13 cm	15 x 5 in	38 x 13 cm	15 x 5 in	38 x 13 cm

Power

Power source	24 V DC (four 6 V 225 Ah batteries)	24 V (four 6 V 225 Ah batteries)	24 V (four 6 V 225 Ah batteries)
Hydraulic system capacity	4.5 gal	17 L	4.5 gal
			17 L

Weight****

ANSI/CSA	3,977 lbs	1,804 kg	4,312 lbs	1,956 kg	5,211 lbs	2,364 kg
----------	-----------	----------	-----------	----------	-----------	----------

Standards Compliance ANSI A92.6, CSA B354.2, CE Compliance, AS 1418.10

* The metric equivalent of working height adds 2 m to platform height. U.S. adds 6 ft to platform height.
 ** Gradeability applies to driving on slopes. See operator's manual for details regarding slope ratings.
 *** Weight will vary depending on options and/or country standards.

Features

Standard Features

Measurements

GS-2046

- 26 ft (8.10 m) working height
- Up to 1,200 lbs (545 kg) lift capacity

GS-2646

- 32 ft (9.92 m) working height
- Up to 1,000 lbs (454 kg) lift capacity

GS-3246

- 38 ft (11.75 m) working height
- Up to 700 lbs (318 kg) lift capacity

Productivity

- 89 x 45.3 in (2.26 x 1.15 m) steel platform
- 36 in (.91 m) extension deck
- Folding rails with full height swing gate
- Drive at full height
- Dual front wheel drive
- Universal 20 amp smart charger
- Rear recessed charger receptacle
- SmartLink™ - proportional lift and drive
- Platform control with battery charge indicator and diagnostic display
- On-board diagnostic system
- AC power to platform
- Lanyard attachment points
- Manual platform lowering valve
- Emergency stop at both platform and ground controls
- Rear wheel multiple disc brakes
- Front wheel hydraulic dynamic braking
- Manual hydraulic brake release
- Swing-out component trays
- Solid non-marking tires
- Pothole guards
- Tilt level sensor with audible alarm
- Descent alarm
- Electronic horn
- Hour meter
- Motion alarm

Power

- 24 V DC (four 6 V 225 Ah batteries)

Options & Accessories

Productivity Options

- Air line to platform
- Dual flashing LED beacons
- Automotive horn*
- Biodegradable hydraulic fluid

Power Options

- Power inverter (120 V/60 Hz)*
- EE rating
- AGM maintenance-free batteries



* Not available with EE rating