

### Performance

Platform Height–Elevated		
1930ES	5.72 m	
2032ES	6.10 m	
2632ES	7.77 m	
2646ES	7.92 m	
3246ES	9.68 m	
Platform Capacity		
1930ES	230 kg	
2032ES	360 kg	
2632ES	230/360 kg	
2646ES	450 kg	
3246ES	320/450 kg	
Capacity on Platform Extension		
	120 kg	
Lift/Lower Time		
1930ES	26/30 seconds	
2032ES	28/40 seconds	
2632ES	33/37 seconds	
2646ES	41/50 seconds	
3246ES	55/62 seconds	
Maximum Drive Height		
	Fully Elevated	
Weight*		
1930ES	1,575 kg	
2032ES	2,000 kg	
2632ES	2,145 kg	
2646ES	2,765 kg	
3246ES	2,940 kg	
Drive Speed–Elevated		
	0.8 km/h	
Drive Speed–Lowered		
1930ES	4.82 km/h	
2032ES/ 2632ES	4.43 km/h	
2646ES/ 3246ES	4.00 km/h	
Gradeability		
	25%	
Turning Radius (Inside)		
	Zero	
Turning Radius (Outside)		
1930ES	1.75 m	
2032ES/ 2632ES	2.06 m	
2646ES/ 3246ES	2.41 m	

\* Certain options or country standards will increase weight.

### Standard Specifications

#### Power Source

Batteries	4x6V 220 amp-hr	
Charger	20 Amp Automatic	
Drive	24V Electric	8hp

#### Hydraulic Reservoir

- Capacity
 

1930ES/2032ES/2632ES	4.73 L
2646ES/3246ES	6.4 L
- Pump
 

Fixed Displacement Gear
-------------------------

#### Tyres

- Tyre Size/Type
 

1930ES	12.5 x 4 in. Non-Marking Solid
2032ES/2632ES/2646ES/3246ES	16 x 5 in. Non-Marking Solid

#### Brakes

- Electric/Friction



### Standard Features

- Proportional Controls
- Industry Leading Duty Cycles
- Self Closing and Locking Gate
- Battery Condition Indicator
- Fold-Down Guard Rails<sup>1</sup>
- Slide-Out Battery Trays
- Automatic Traction Control (ATC)
- All Motion Alarm
- 20 Amp Automatic SCR Charger
- Horn
- Hourmeter
- Manual Descent Pull Cable
- Tilt Alarm and Light
- Moveable, Removable Platform Control
- Powder-Coated
- Console with Rail Mounting Bracket
- Nickel Plated Pins
- Lubrication Free Scissor Arm Bushings
- Scissor Maintenance Prop
- Mechanised Pothole Protection
- Machine Tie Downs
- Fork Lift Pockets, Lift from Side and Rear
- Flashing Amber Beacon
- Load Sensing System
- Lifting Lugs

### Accessories & Options

- AC Outlet in Platform
- White Noise (squawker) Motion Alarm
- AGM Batteries
- Airline to Platform
- Special Hydraulic Oils
- Accessory Packages:
  - Electrician's Package
  - Plumber's Package
  - JLG® Workstation
  - Panel Carrier Accessory<sup>1</sup>
  - Pipe Rack Accessory
  - Plant Maintenance Package

1. Not available on the 1930ES.

### Dimensions

All dimensions are approximate.

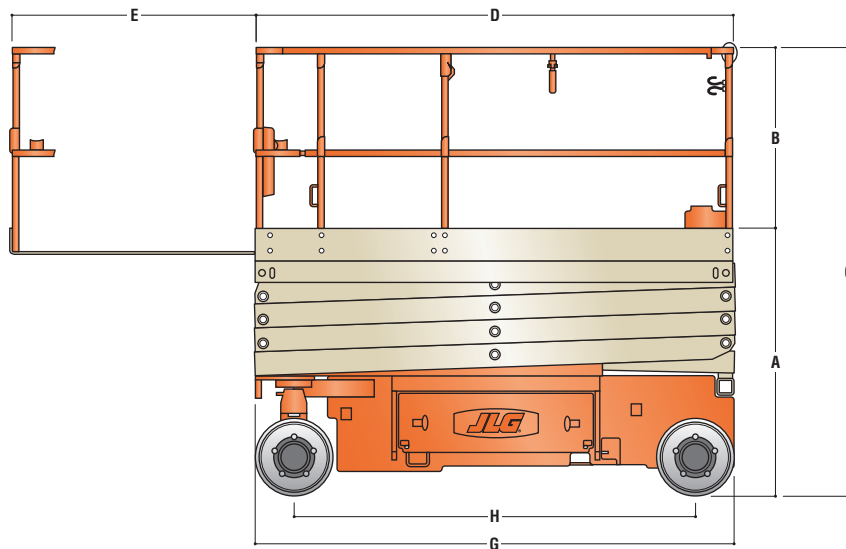
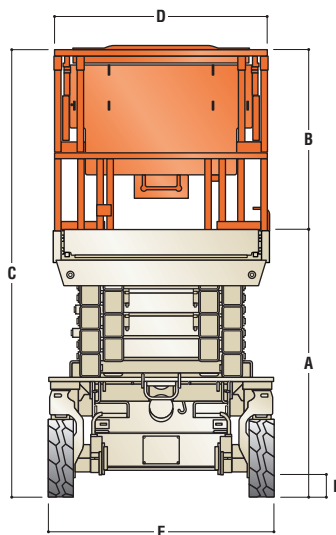

#### A. Platform Height - Lowered

1930ES	0.86 m
2032ES	1.10 m
2632ES	1.23 m
2646ES	1.26 m
3246ES	1.26 m

#### B. Platform Railing Height ES Series

1.14 m

#### C. Overall Height

1930ES - Fixed rails	1.99 m
1930ES - Fold Down Rails, Up	2.02 m
1930ES - Rails Folded	1.52 m
2032ES - Fold Down Rails, Up	2.20 m
2032ES - Rails Folded	1.87 m
2632ES - Fold Down Rails, Up	2.33 m
2632ES - Rails Folded	1.98 m
2646ES - Fold Down Rails, Up	2.36 m
2646ES - Rails Folded	1.97 m
3246ES - Fold Down Rails, Up	2.36 m
3246ES - Rails Folded	1.97 m

#### D. Platform Size

1930ES	0.76 x 1.87 m
2032ES/2632ES	0.76 x 2.3 m
2646ES/3246ES	1.12 x 2.5 m

#### E. Platform Extension

1930ES/2032ES/2632ES	0.9 m
2646ES/3246ES	1.27 m

#### F. Overall Width

1930ES	76 cm
2032ES/2632ES	81 cm
2646ES/3246ES	1.17 m

#### G. Overall Length

1930ES	1.87 m
2032ES/2632ES	2.3 m
2646ES/3246ES	2.5 m

#### H. Wheelbase

1930ES	1.6 m
2032ES/2632ES	1.88 m
2646ES/3246ES	2.09 m

#### I. Ground Clearance

1930ES/2032ES/2632ES	8.8 cm
2646ES/3246ES	12.7 cm