

### Specifications

Model	S-85 XC	
Measurements	Metric	US
Working height maximum*	27.91 m	91 ft
Platform height maximum	25.91 m	85 ft
Horizontal reach maximum	22.71 m	74 ft 6 in
Below ground reach	2.69 m	8 ft 10 in
<b>A</b> Platform length	0.91 m	3 ft
<b>B</b> Platform width	2.44 m	8 ft
<b>C</b> Height - stowed	2.80 m	9 ft 2 in
<b>D</b> Length - stowed	12.37 m	40 ft 7 in
Length - transport (jib tucked under)	11.60 m	38 ft
<b>E</b> Width	2.49 m	8 ft 2 in
<b>F</b> Wheelbase	2.85 m	9 ft 4 in
<b>G</b> Ground clearance - center	0.40 m	15.8 in

### Productivity

Maximum lift capacity - unrestricted	300 kg	660 lb
- restricted	454 kg	1,000 lb
Platform rotation	160°	
Vertical jib rotation	135°	
Turntable rotation	360° continuous	
Turntable tailswing	1.60 m	5 ft 3 in
Drive speed - stowed	4.8 km/h	3.0 mph
- raised/extended	0.2 m/s	0.50 mph
Gradeability - stowed**	45%	
Turning radius : inside	3.66 m	12 ft
outside	6.55 m	21 ft 6 in
Controls	12V DC proportional	
Tyres - RT foam filled	18-625, 16 ply	

### Power

Power source	Deutz TD 2011 L04i, 74 hp (55 kW), Stage IIIA	
Auxiliary power unit	12V DC	
Hydraulic tank capacity	151 L	40 gal
Fuel tank capacity - diesel	132 L	35 gal

### Sound & Vibration Levels

Sound pressure level (ground workstation)	83 dBA	
Sound pressure level (platform workstation)	71 dBA	
Vibration	<2.5 m/s <sup>2</sup>	<8 ft 2 in/s <sup>2</sup>

### Weight\*\*\*

4WD	18,126 kg	39,959 lbs
-----	-----------	------------

### Standards Compliance

AS/NZS 1418.10

### Range Of Motion S-85XC

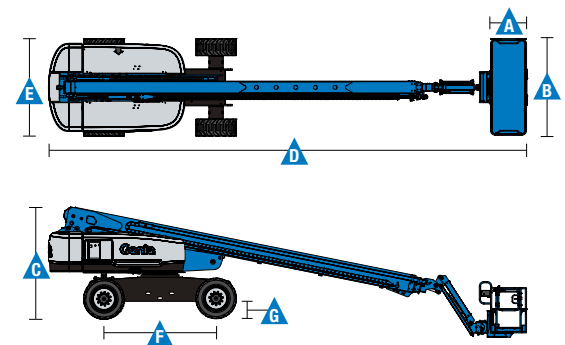
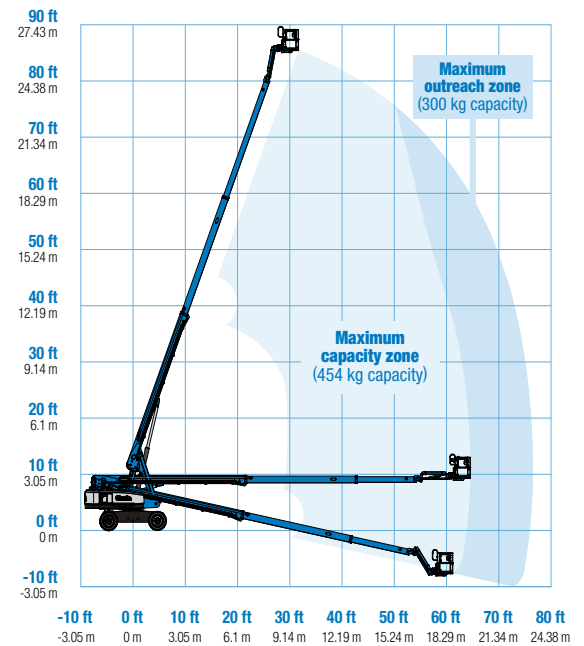

\* The metric equivalent of working height adds 2 m to platform height. U.S. adds 6 ft to platform height.

\*\* Gradeability applies to driving on slopes. See operator's manual for details regarding slope ratings.

\*\*\*Weight will vary depending on options and/or country standards.

## Features

### Standard Features

#### Measurements

- 27.91 m (91 ft) working height
- 22.71 m (74 ft 6 in) horizontal reach
- 300 kg (660 lb) unrestricted and 454 kg (1,000 lb) restricted lift capacity

#### Productivity

- Steel 2.44 m (8 ft) tri-entry platform with side swing gate
- Self-leveling platform
- 160° hydraulic platform rotation
- Thumb rocker steering
- Proportional joystick controls
- Hydraulic oil cooler
- Drive enable system
- Chassis tilt drive function cut-out
- AC power cord to platform
- Horn
- Hour meter
- Tilt alarm
- Descent motion & travel alarms
- Flashing beacon
- 360° continuous turntable rotation
- Positive traction drive
- Two speed wheel motors
- On board full diagnostics
- Dual battery system
- Telematics ready connector
- Lift Guard<sup>™</sup> Contact Alarm
- Lockable platform & ground control box covers

#### Power

- Lift Power<sup>™</sup> 7.5 kW generator, 240V/50Hz
- 12 V DC auxiliary power
- Anti-restart engine protection
- Auto engine fault shutdown
- Deutz intake air heater
- Deutz Stage IIIA turbo diesel 55 kW (74 hp)

#### Drive

- 4 x 4

#### Axle

- Active oscillation

#### Tyres

- Rough terrain non-marking foam-filled

### Options & Accessories

#### Productivity Options

- Half-mesh platform inserts
- Air line to platform
- Work lights package
- Biodegradable hydraulic oil
- Operator Protective Structure
- Fall arrest bar

#### Power Options

- Diesel catalytic purifier muffler
- Diesel catalytic scrubber muffler

