

Specifications

MODEL	TZ-50	
-------	-------	--

Measurements	US	Metric
Working height*	55 ft 6 in	16.92 m
Platform height	49 ft 6 in	15.09 m
Entry height	1 ft 8 in	.51 m
Horizontal reach	29 ft 2 in	8.89 m
Clear outreach	23 ft 1 in	7.04 m
Up and over clearance	22 ft	6.71 m
A Platform length	2 ft 2.8 in	.68 m
B Platform width	3 ft 8 in	1.12 m
C Height - stowed	6 ft 10 in	2.08 m
D Length - stowed	23 ft 6 in	7.16 m
E Width - stowed	5 ft 6 in	1.68 m
F Ground clearance - center	10 in	.25 m
G Length - outrigger footprint	14 ft 4 in	4.37 m
H Width - outrigger footprint	14 ft 4 in	4.37 m

Productivity		
Lift capacity (ANSI, CSA) - standard	500 lbs	227 kg
Lift capacity (ANSI, CSA) - rotating platform	500 lbs	227 kg
Lift capacity (CE/AUS) - standard	440 lbs	200 kg
Lift capacity (CE/AUS) - rotating platform	440 lbs	200 kg
Jib boom	4 ft 1 in	1.25 m
Jib working range	135°	
Self leveling platform	2.5° standard	
Platform rotation option	160° hydraulic	
AC power to platform	standard	
Turntable rotation	359° non-continuous	
Outrigger leveling capability	11°	
Drive speed	0.85 mph	1.37 km/h
Gradeability**	20%	
Towing speed rate	60 mph	97 km/h
Tongue weight - ANSI, CSA	400 lbs	181 kg
Tongue weight - CE	220 lbs	100 kg
Surge and parking brakes	standard	
Controls	variable speed system	
Tires - ANSI, CSA	ST 225/75 R15	
Tires - CE	215 R14C	
Coupler	combination hitch	

Power		
Power source - standard	24V DC (four 6V 225 Ah batteries)	
Power source - drive option	24V DC (four 6V 244 Ah batteries)	
Power source - option	Hybrid DC/Gas Honda 5.5 hp (4.1 kW)	
Fuel tank capacity	.95 gal	3.6 L
Hydraulic tank capacity	4.75 gal	18 L
Hydraulic system capacity	8.0 gal	30 L

Weight***		
ANSI, CSA, Australia	4,400 lbs	1,996 kg
CE	4,475 lbs	2,030 kg

Standards Compliance ANSI A92.2, CSA C225, EN 280, AS 1418.10

Range Of Motion TZ-50

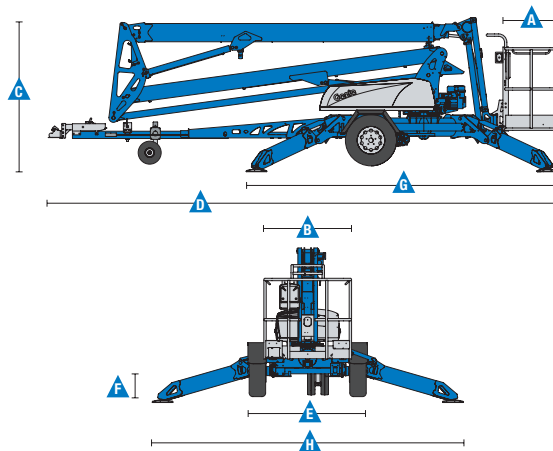
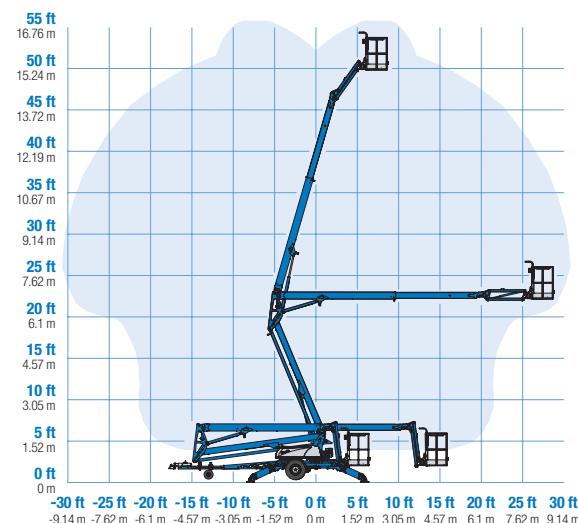

* The metric equivalent of working height adds 2 m to platform height. U.S. adds 6 ft to platform height.

** Gradeability applies to driving on slopes. See operator's manual for details regarding slope ratings.

*** Weight will vary depending on options and/or country standards.

Features

Standard Features

Measurements

- 55 ft 6 in (17.09 m) working height
- 29 ft 2 in (8.89 m) horizontal reach
- Up to 500 lbs (227 kg) lift capacity

Productivity

- Industry leading working envelope
- Extension boom
- Self-leveling platform
- 4 ft jib with 135° working range
- AC wiring to platform
- Hydraulic outriggers
- Automatic 11° leveling system
- Outrigger interlocks
- Mechanical parking brake
- Hydraulic surge brakes
- Adjustable hitch with coupler lever lock
- Dual jockey wheels
- 359° non-continuous turntable rotation
- Easy to access batteries
- Hour meter
- Tilt alarm / sensor
- Illuminated outrigger indicators
- Highway safety chains with snap hook
- LED brake lights (ANSI, CSA)

Power

- 24V DC power source (four 6V 225 Ah batteries)

Configurations

Platform Options

- Aluminum 26.8 x 44 in (.68 x 1.12 m)
- 160° hydraulic platform rotation

Power Options

- 24V DC power source
- Hybrid Honda 5.5 Hp (4.1 Kw) 45 amp charging system

Drive

- Drive and set option (ANSI, CSA, AUS)
- Drive only (CE)

Coupler Options

Adjustable hitch

- 2 in (5.08 cm) ball coupler
- 2 ⁵/₁₆ in (5.87 cm) ball coupler
- 2 ¹/₂ in (6.53 cm) I.D. pintle ring coupler
- Clevis coupler

Tire Options

- ST 225/75 R15 tires (ANSI, CSA)
- 215 R14C tires (CE)

Options & Accessories

Productivity

- 160° hydraulic platform rotation
- Drive and set option
- Wheel chocks
- Fluorescent tube caddy
- Full size spare tire
- Flashing beacon
- Non-marking outrigger footpads
- Battery charge indicator (BCI)
- Tool tray
- Horn
- High capacity battery
- Ladder option (CE and AUS only)

Power

- Hybrid Honda 5.5 Hp (4.1 Kw) 45 amp charging system option

