

# JIBBI 1670-EVO

## CRAWLER TELESCOPIC BOOM

**ACCESS**  
**SOLUTIONS**

Experience | Safety | Innovation

### ADDED BENEFITS

- Maximum Working height: 16m
- Moving Height: 9.8m
- Max basket capacity: 230 Kg
- Total Weight: 3850 Kg
- Basket rotation +/- 70°
- Slewing ring rotation +/- 110°
- Max gradeability 25°
- Proactive levelling
- Dynamic levelling
- Longitudinal & lateral levelling +/- 15°



**ACCESS SOLUTIONS**

0800 656 343 [www.accesssolutions.co.nz](http://www.accesssolutions.co.nz)

**AUCKLAND**  
100 Leonard Road  
Mt Wellington  
Auckland

**WAIKATO**  
280a Peake Road  
Hautapu  
Cambridge

**CHRISTCHURCH**  
28 Nga Mahi Road  
Sockburn  
Christchurch

# JIBBI 1670 EVO

16 mt crawler telescopic boom.

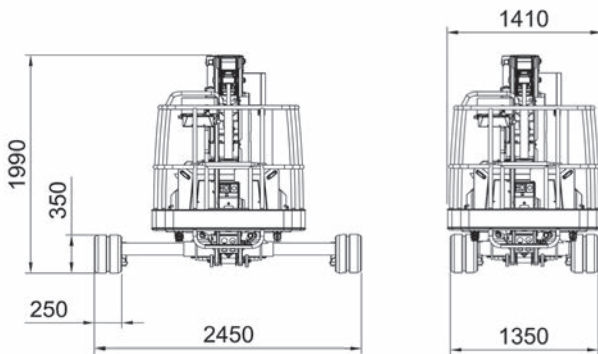
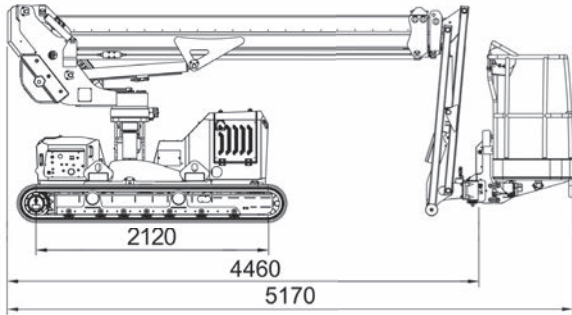

## Integrated Drive System

Using single joystick



Cable remote console by AUTECH

## MyAlmac CONTROL PANEL



Machine settings remote control panel

Basket rotation

+/- 70°



Slewing ring rotation

+/- 110°



Resizable undercarriage

1.35 / 1.90 / 2.45 mt



## Technical data

## JIBBI 1670 EVO

Max working height	16,00 m
Max height basket floor	14,00 m
Moving height	9,00 m
Max outreach (load 80 kg)	8,50 m
Max outreach (load 140 kg)	7,70 m
Max outreach (load 230 kg)	6,70 m
Rotation angle	+/- 110°
Basket size	1,40 x 0,70 m
Basket rotation angle	+/- 70°
Max basket capacity	230 kg
Length in stowed position (with detached basket)	5,10 (4,40) m
Min width in stowed position	1,35 m
Medium working width	1,90 m
Max working width	2,45 m
Min height in stowed position	1,99 m
Longitudinal leveling	+/- 15°
Lateral leveling	+/- 15°
Max gradeability	25°
Max side gradeability	25°
Drive speed (fast)	2,50 km/h
Speed over transport condition	0,40 km/h

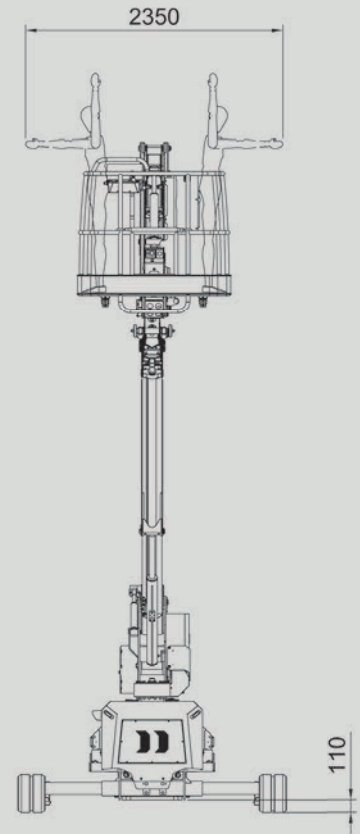

## Weights

Traffic load (max working width)	3,10 KN/m <sup>2</sup>
Total weight	3850 kg

## Power

3TNM68 -AS Yanmar engine (diesel)	14 kW - 19,2 Hp @3600rpm
-----------------------------------	--------------------------

## Extras - On Demand

Wide Basket	1,80 x 0,70 m
Non-marking tracks	-
Electric pump 220V-2,2KW / 50Hz (Weight +30 Kg)	-
Radio remote control with rechargeable battery	-
Arctic lubricant for cold climate	-
Winch kit 200 kg	-
Ultrasonic Anti-collision System	-

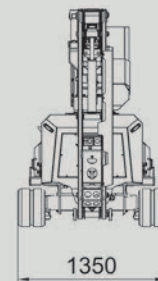

## Basket size

Standard  
1.4 mt

Optional  
1.8 mt



# JIBBI 1670 EVO

- 80 kg
- 140 kg
- 230 kg

<b>16.0m</b>	<b>230kg</b>	<b>19.2Hp</b>	<b>+/-15°</b>	<b>2.5 km/h</b>	<b>+/-15°</b>
MAX W.H.	CAPACITY	POWER	LONG. LEVEL.	SPEED	LATER. LEVEL.

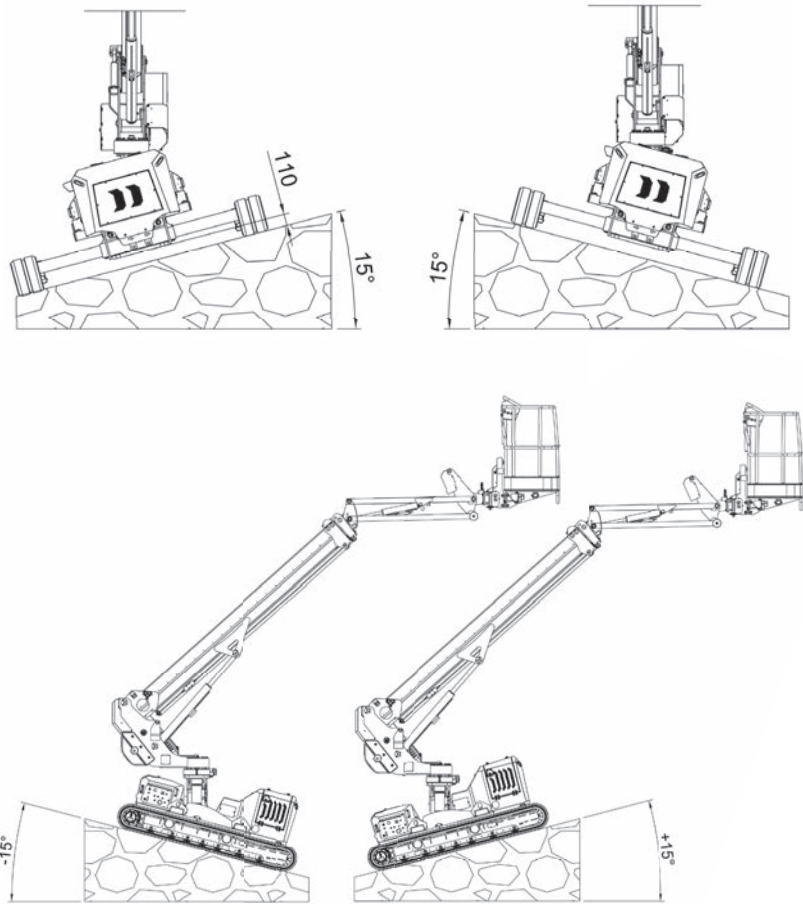
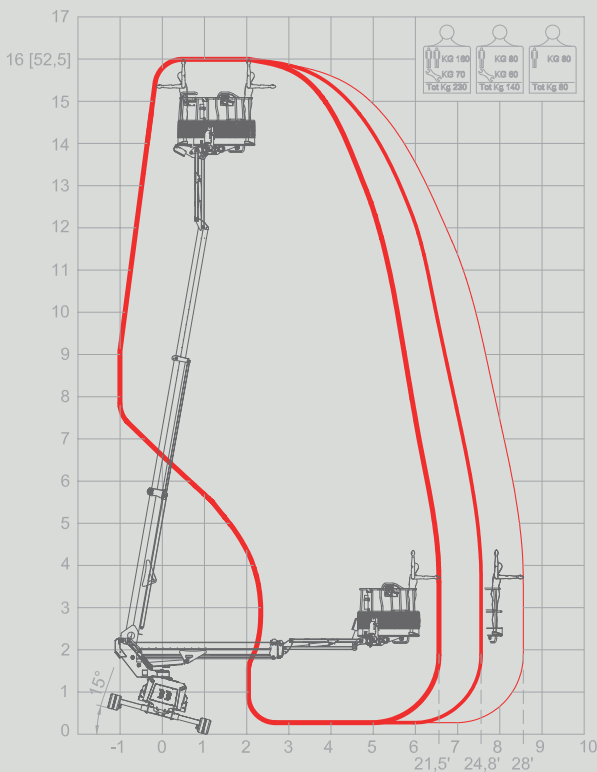
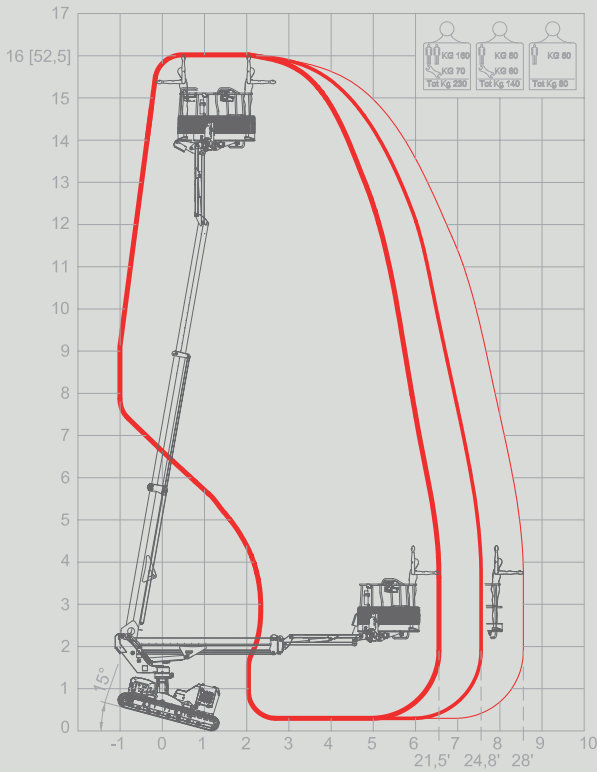

## UNDERCARRIAGE CONFIGURATIONS & WORKING AREAS

