

# 600AJ HC3

## ARTICULATING HI-CAPACITY BOOM LIFT



Experience | Safety | Innovation

### Performance

Platform Height	60 ft	18.3 m
Horizontal Outreach	40 ft 6.9 in.	12.37 m
Up and Over Clearance	26 ft 6.4 in.	8.1 m
Swing	360 Degrees Continuous	
Platform Capacity		
600AJ HC3 - Restricted	750/1000 lb	340/454 kg
600AJ HC3 - Unrestricted	660 lb	300 kg
Platform Rotator	180 Degrees Hydraulic	
Jib Range of Articulation	130 Degrees (+70, -60)	
Weight		
600AJ HC3	26,057 lb	11,819 kg
Max. Ground Bearing Pressure		
600AJ HC3	96 psi	6.75 kg/cm2
Drive Speed 4WD	4.25 mph	6.8 kph
Gradeability 4WD	45%	
Tilt Cut Out	5 Degrees	
Axle Oscillation	8 in. 0.2 m	
Turning Radius		
Inside	7 ft 6 in.	2.15 m
Outside	16 ft 11.3 in.	5.17 m

### Standard Specifications

#### Power Source

Dual Fuel Engine		
Ford MSG425	84 hp	62 kw
Diesel Engine		
Deutz D2.9L4 Tier 4 Final	49 hp	36.4 kw
Fuel Tank Capacity	30 gal.	113.6 L

#### Hydraulic System

Capacity	30.6 gal.	115.8 L
Auxiliary Power	12V DC	

#### Tires

Standard	IN355/55D-6.25 Foam Filled
----------	----------------------------

### Standard Features

- Oscillating Axle
- 180 Degree Hydraulic Platform Rotator
- 110V-AC Receptacle in the Platform
- 5 Degree Tilt Alarm/Indicator Light
- Swing-Out Engine Tray
- 12V-DC Auxiliary Power
- Hourmeter
- Horn
- Control ADE® System
- Proportional Controls
- Gull-Wing Engine Hood
- LED Light Panel at Platform and Ground Control Consoles
- Status Light Panel\*
- Lifting/Tie Down Lugs
- All Motion Alarm
- Glow Plugs (Diesel Engines)
- Load Sensing System
- SkyGuard SkyLine™

# HC3

3 Capacity Zones - Each rated for 3 occupants + tools/materials



### Accessories & Options

- Platform: 36 x 72 in. (0.91 x 1.83 m)
- Fall Arrest Platform, Rear Entry: 36 x 96 in. (0.91 x 2.44 m)
- Self-Closing Gate
- SkySense™
- Soft Touch System
- Operator Tool Tray
- 43.5 lb (19.7 kg) Propane Tank
- Cold Weather Package<sup>1</sup>
- Hostile Environment Kit<sup>2</sup>
- Flashing Amber Beacon
- Arctic Package<sup>3</sup>
- Accessory Packages:
  - SkyPower®
  - SkyWelder®

\* Provides indicator lights at platform and ground control consoles to show system distress, 5 degree tilt light, and foot switch status.

1. Includes Battery Blanket, Hydraulic Tank Heater, Block Heater.

2. Includes console cover, boom wipers and cylinder bellows.

3. Includes Arctic Hydraulic Hoses (Drive, Steer), Main Boom Cable, Extreme Cold Engine Oil, Fuel Conditioner, Engine Block Heater, Battery Blanket, Glow Plugs, Hydraulic Tank Heater, Oversized Footswitch And Arctic Hydraulic Oil.

Note: Some options may increase lead time, and some option combinations may not be available.

Additional accessories and options available via JLG Aftermarket.

# ACCESS SOLUTIONS

0800 656 343 [www.accesssolutions.co.nz](http://www.accesssolutions.co.nz)

**AUCKLAND**  
100 Leonard Road  
Mt Wellington  
Auckland

**WELLINGTON**  
33 Broken Hill Road  
Porirua  
Wellington

**CHRISTCHURCH**  
28 Nga Mahi Road  
Sockburn  
Christchurch

# 600AJ HC3

## ARTICULATING HI-CAPACITY BOOM LIFT



Experience | Safety | Innovation

### Dimensions

All dimensions are approximate.

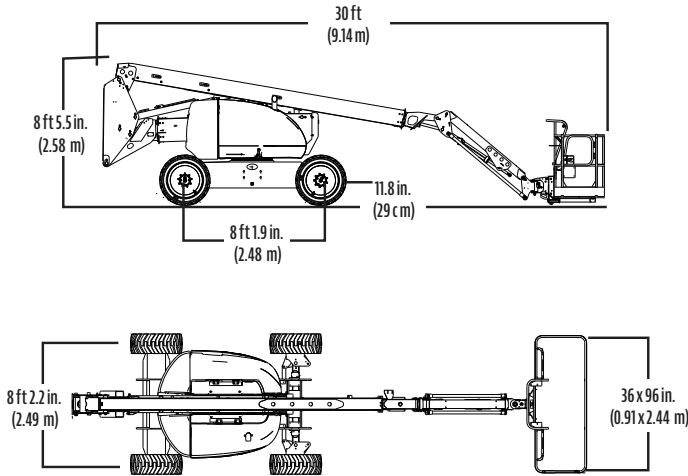

### Reach Diagram

