

MONITOR RR14 EVO3/400 RAIL BOOM LIFTS



Experience | Safety | Innovation



MONITOR RR14 EVO3/400 RAIL BOOM LIFT



MONITOR RR14 EVO3/400

This is not a modified Boom Lift. The RR14 EVO has been specifically designed from the ground up for use on rail, and has a host of unique features to provide fast and safe access above both rail and normal terrain.

In the creation of the machine, a lot of attention has been given to meet the stringent industry requirements, resulting in unmatched performances.

The self-levelling turret and very strong chassis allows an amazing horizontal outreach of 9.3 m when set-up on rail. Not only this, but the RR14 EVO will also drive whilst elevated, greatly improving work efficiencies.

Available in a tri-gauge version, the RR14 EVO can be used on all three rail gauges in Australasia. It is available with the option of direct hydraulic drive, 4 Wheel Steer for superior performance

and handling.

Every rail industry requirement has been thought of and catered for, with an emergency back-up diesel engine, electric emergency lowering system and directional LED lights through to the options of an on-board generator, work area lighting, anti-crush device, rail equipment position indication and EDD's.

An optional pantograph is available for measuring the height and distance of overhead wires. A data recorder and GPS device stores inspection data for referencing.

OPTIONAL ADD-ONS:

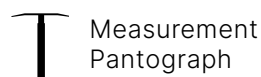



MONITOR RR14 EVO3/400 - RAIL BOOM LIFTS



TECHNICAL SPECIFICATIONS

Working Diagram on Road 400kg

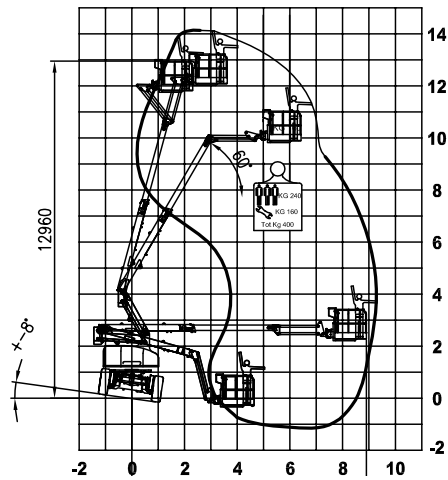

Working Diagram on Rail 400kg

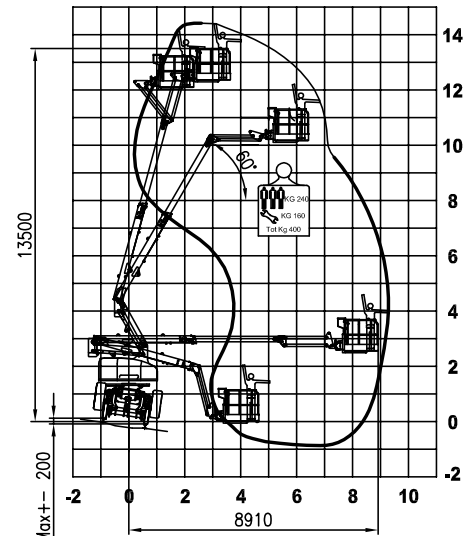

(Diagrams relate to Std Gauge 1435mm rail).

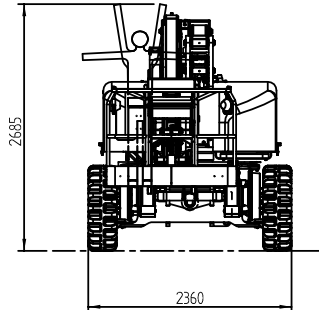
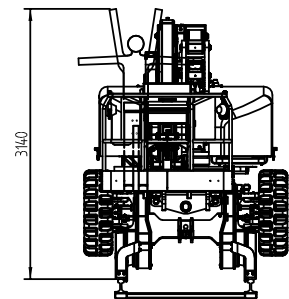
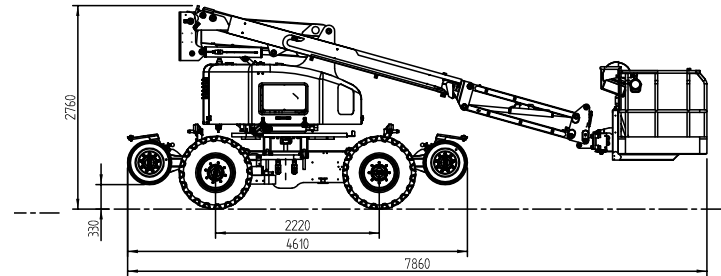
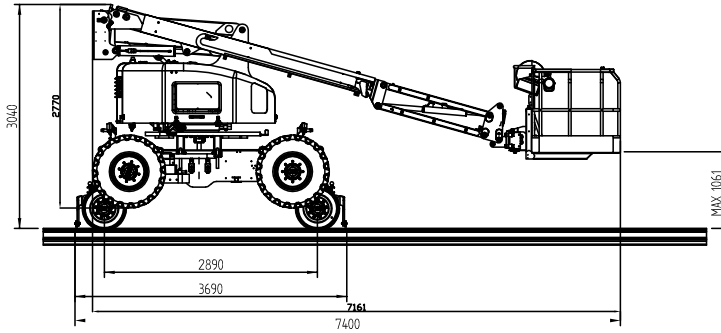

(2540 with new hub design)
(2450 to hubs with wheels reversed - 2420 to tyres)
(2495 with wheels reversed on one side only)

Max working height	rail 14.4 m (tyres 14.10 m)
Max working height in narrow set	N/A
Max horizontal outreach	rail 9.3 m (tyres 10.20 m)
Max. rated capacity	3 persons / 400 kg
Weight (approx)	13,400 kg
Turret rotation	359°
Basket rotation	180°
Ground pressure driving (approx)	kN/m ²
Traffic load (live load) travelling	kN/m ²
Auto levelling turret	Std
Gradeability lengthwise	16°
Gradeability sideways	8° rail (14° tyres)
Standard power source	Hatz 48 Hp Diesel
Optional power source	Emergency Hatz 9 Hp Diesel
Dual power options	Hybrid w/ Lithium Batteries
Tri-gauge	Optional
Drive Speed	Rail 18 km/h (Road 8 km/h)
Electric emergency lowering	Std

(All specs E&OE and subject to change)

Note: Specifications vary between models as well as with rail gauge changes. For more detailed information on the RR14 EVO, please contact Monitor Lifts.



MONITOR RR14 EVO3/400 - RAIL BOOM LIFTS



STANDARD FEATURES OF THE MONITOR RR14



**4 Wheel Steer & 4 Wheel
direct hydrostatic Drive**

with option of 18 km/h drive speed on rail

± 8° Self-leveling turret



400 kg MRC

3 person large basket



MONITOR RR14 EVO3/400 - RAIL BOOM LIFTS



OPTIONAL ACCESSORIES

Lithium Battery

With a more efficient technology that is environment friendly with the reduction of noise and emissions, and increased safety.

It boasts a fully electric solution that enables it to be used in any situation—including operating inside a tunnel—with low noise, and no emissions.



Measurement Pantograph

Designed to fit to the RR14 EVO3, it is very compact in size to maximize the machine's manouverability, retracting to a stowed height position of only 3m.

This enables the machine to be transported on trucks without having to remove the pantograph.



GET IN TOUCH



ACCESS SOLUTIONS

0800 656 343 www.accesssolutions.co.nz

AUCKLAND
100 Leonard Road
Mt Wellington
Auckland

WELLINGTON
33 Broken Hill Road
Porirua
Wellington

CHRISTCHURCH
28 Nga Mahi Road
Sockburn
Christchurch



MONITOR RR14 EVO3/400 - RAIL BOOM LIFTS

